

Doubly Fed Induction Machine Drive Distance Learning Laboratory for Wind Power and Electric Ship Propulsion Applications

Giovanna Oriti, Alexander L. Julian, Dan Zulaica
Naval Postgraduate School

A state of the art FPGA based **Student Design Center (SDC)** has been applied to research and curriculum at the Naval Postgraduate School for the last five years. A **web-interface** was recently created to make the SDC available to remotely located students taking **Distance Learning (DL)** courses. This DL laboratory allows the remote student to experimentally verify the operation of a DFIM drive system emulating a wind power turbine connected to the grid or a bidirectional drive for ship propulsion applications. The power electronics is controlled by two FPGA based controllers which communicate with a web server PC through a USB interface so that the laboratory can be executed on campus as well as remotely. The remote students only need access to a PC with internet connection and a standard browser, without the need to install any software or modify its security settings.

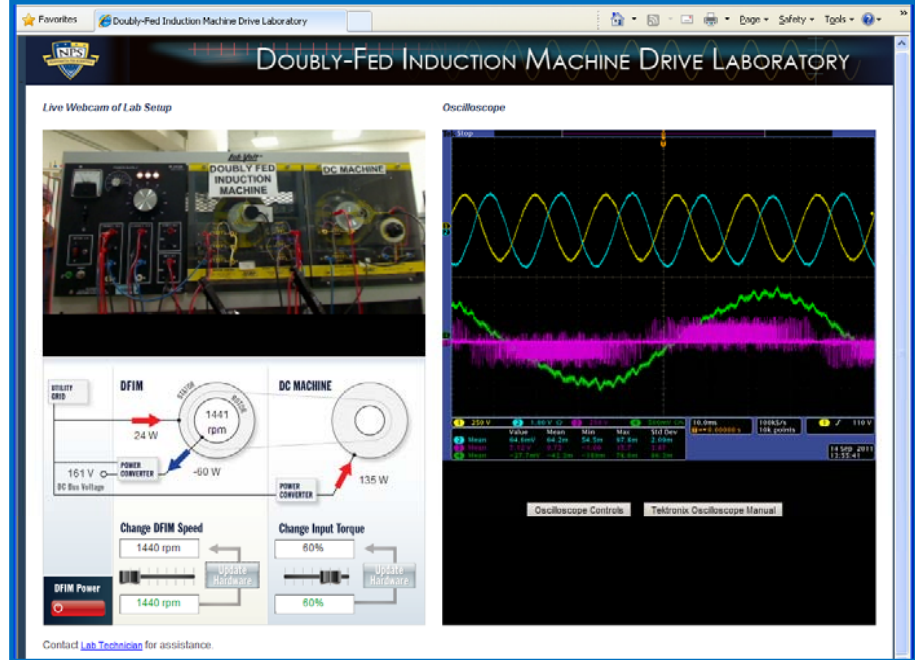

Screen Capture of the Lab Graphic User Interface in a standard Web Browser

Block Diagram of the Embedded Electronics in the SDC

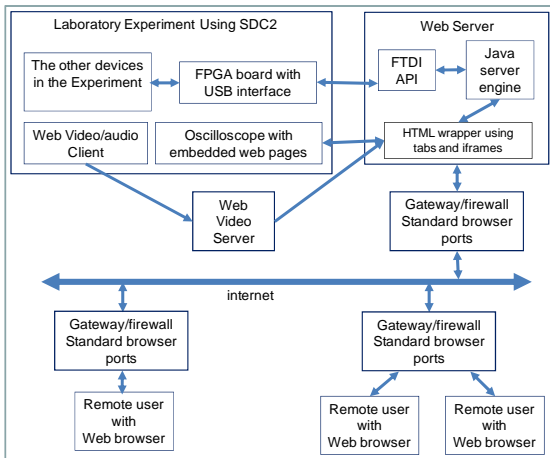
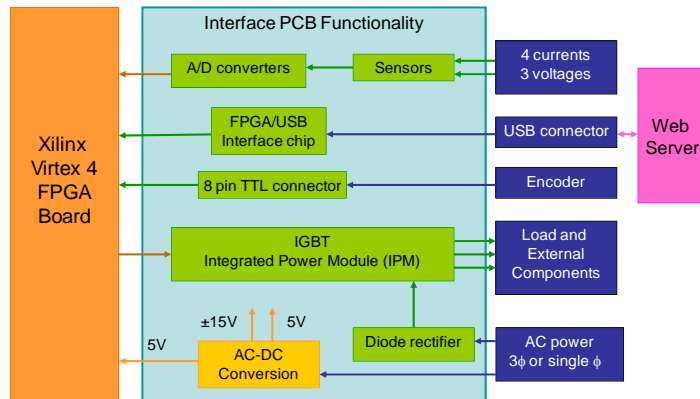

How the Lab is Made Available to Remote Students

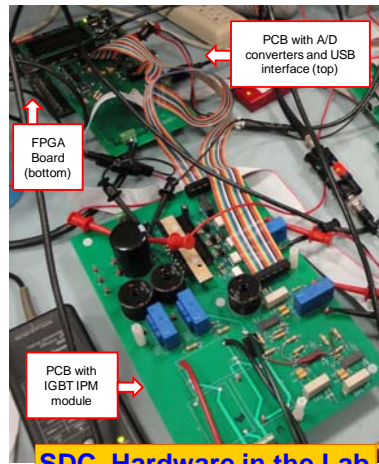

SDC Hardware in the Lab

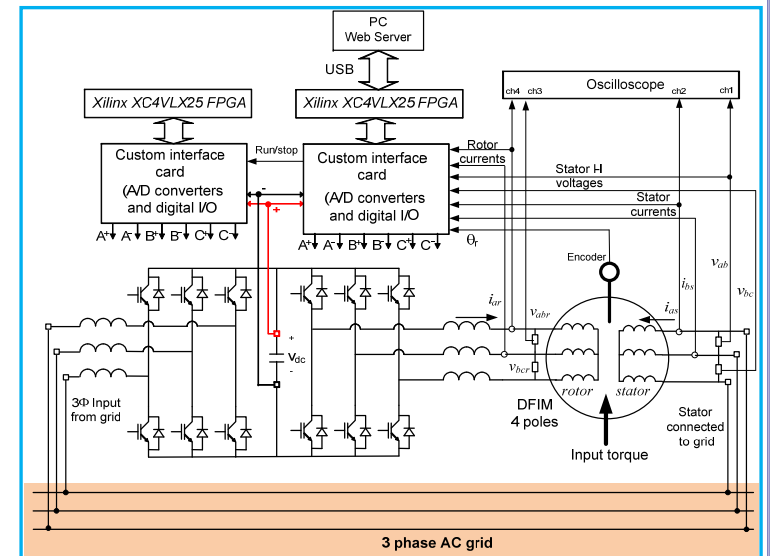

DFIM Drive as Implemented in the Lab