

Curriculum Reform in Electric Energy Systems

With Emphasis on

- Renewables/Storage
- Reliable Delivery
- Efficient End-Use

Wind



Solar



Role of Power Electronics

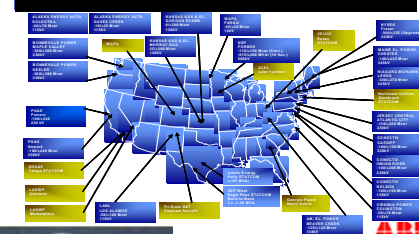

ABB



Hybrid



Fuel Cells



CFL

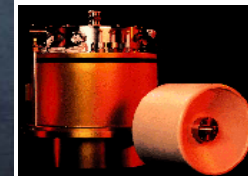

Flywheels for Storage

ONR-NSFEPRI-AEP Sponsored Workshop
Napa, CA 12-15, 2009

Group Effort:

- Ned Mohan
- Bill Robbins
- Bruce Wollenberg
- Paul Imbertson
- Tom Posbergh
- Dr. Narain G. Hingorani (Consultant)
- Ron Fitch (Distance Learning)
- Heather Dorr and Josette Barsness (Organization)
- Students

www.ece.umn.edu/groups/power

Center for Electric Energy

■ History

- ◆ Established in 1981 by Prof. Vern Albertson
- ◆ Present Director - Prof. Bruce Wollenberg
- ◆ Supported by 7 Regional Utilities
- ◆ Budget: ~178 k\$/year

Past Sponsors:

Lab Development Grants:

- NSF
- NASA
- ONR

Initial Dissemination Grant:

Present ONR Dissemination Grant:

Program Officer: Terry Ericson

(1.23 Million Dollars over 5 years)

Supported by:

1. Electric Power Research Institute (EPRI)

Clark Gellings: VP-Technology

Rosa Yang: VP-Innovation

35 k\$ Honorarium to 35 Faculty/yr

2. American Electric Power (AEP):

Ray Hayes

20 k\$/yr to 10 Universities

3. NSF

Dagmar Niebur

10 k\$/yr

Perspectives on Need for Curricular Reform

- Terry Ericson - ONR
- NSF – Barbara Kenny
- EPRI – Clark Gellings
- AEP – Ray Hayes

Outline:

- Crisis
- Opportunities
- Approach
- Results
- Workshop Agenda

Energy Crisis and Climate Change

Production and Consumption

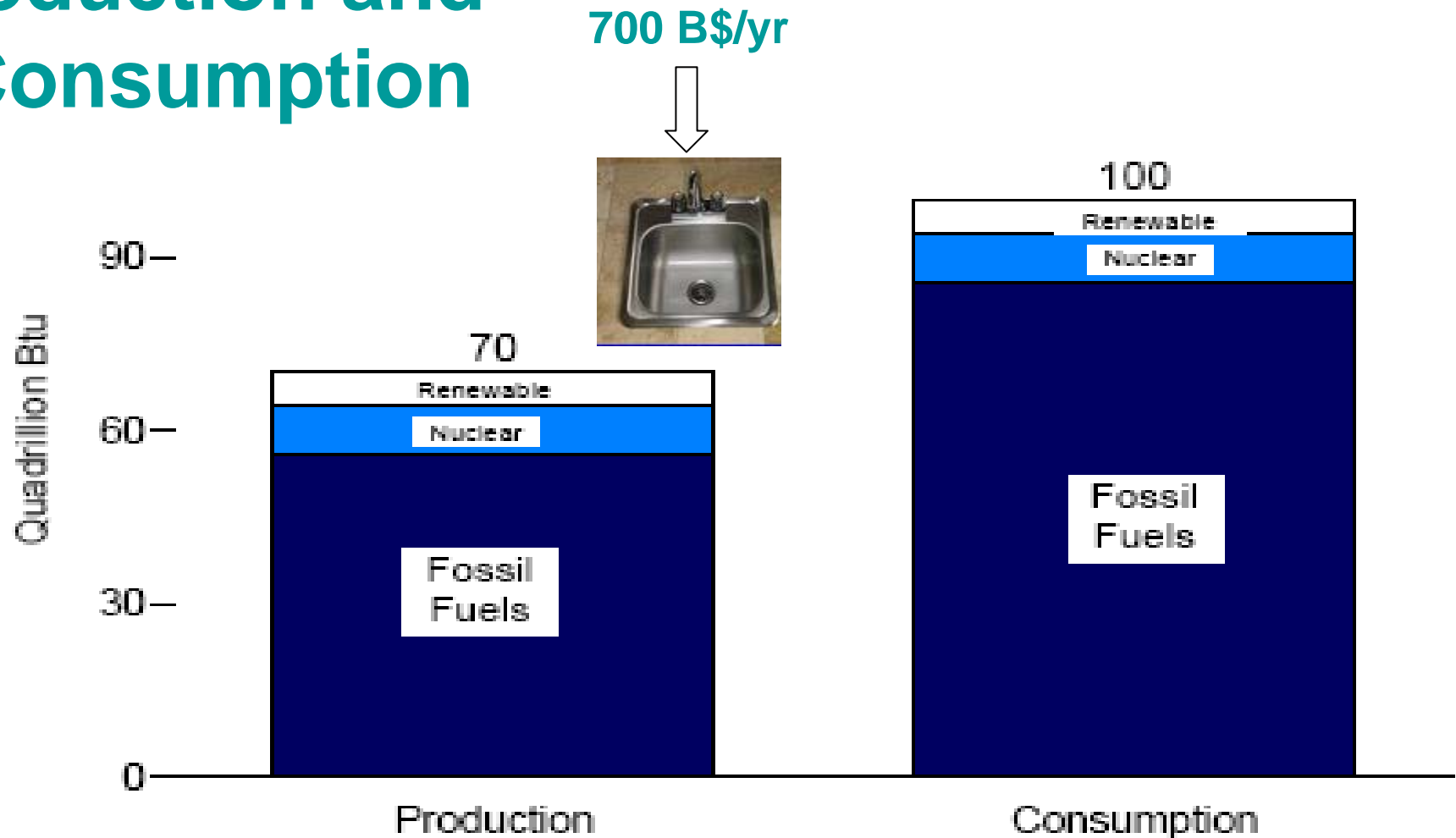

Electric Power as a Percentage

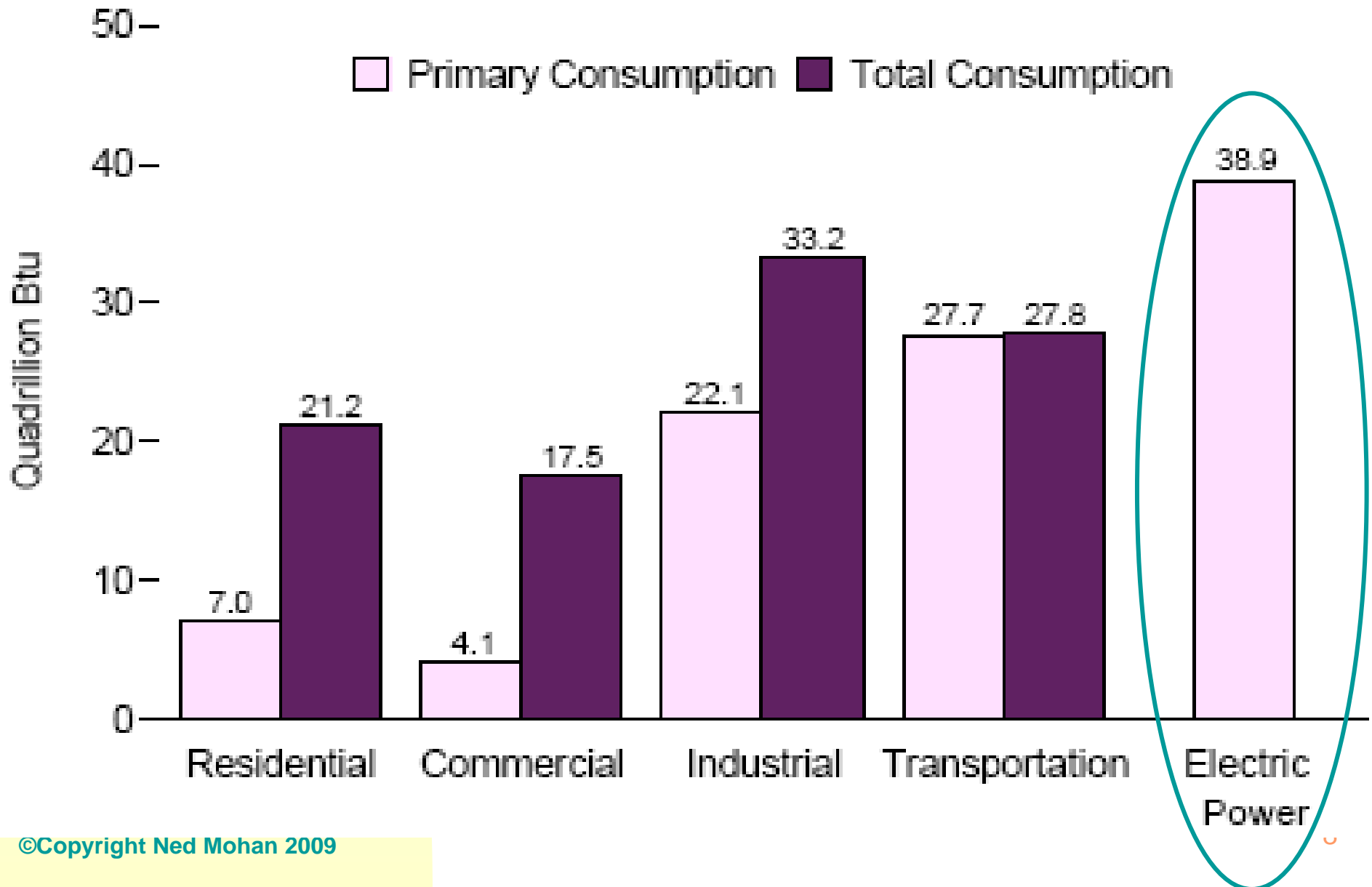

Workforce Crisis:

BPA Workforce:



- 2,944 employees
- Median age is 50
- 21% eligible to retire by 12/07
- 42% eligible to retire by 12/11

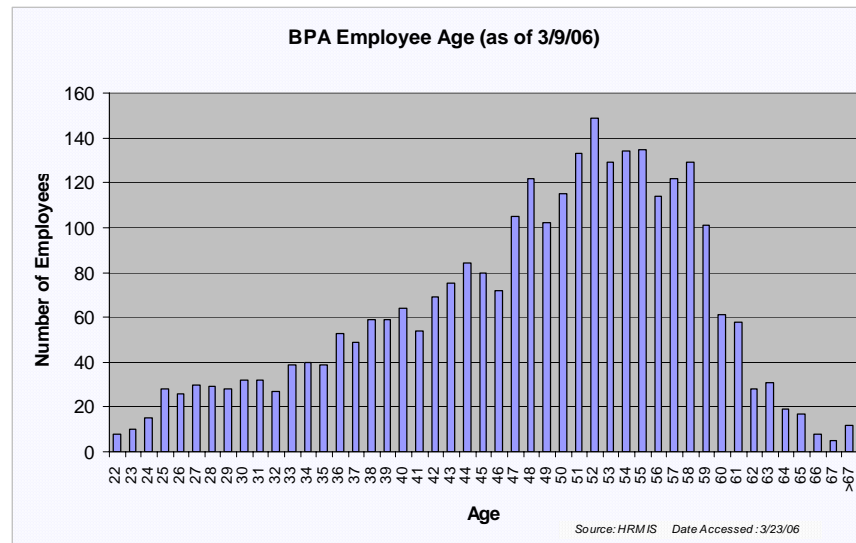

Data Source: HRMIS as of 2/9/06

Source: Clark Gellings, EPRI

Crisis in Undergraduate Education

- Courses have not kept pace with Industrial Practices

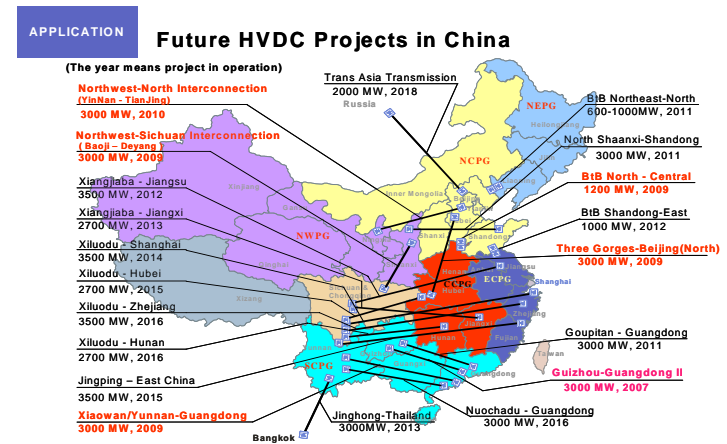
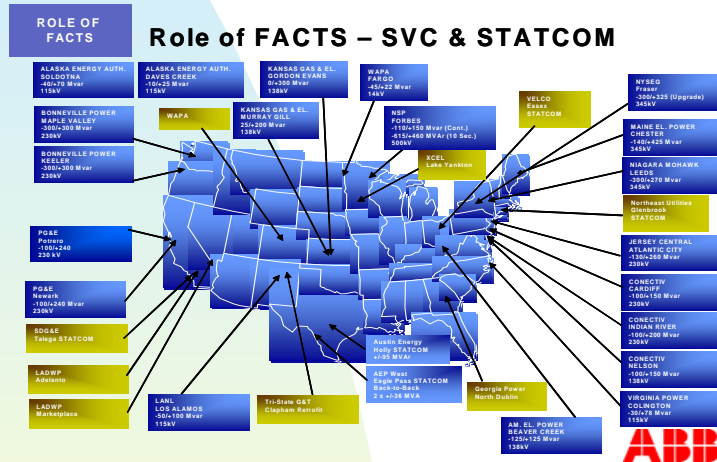

- Power Programs are Stagnating

OPPORTUNITY: Young People are Concerned about the Environment -



We can tap into their enthusiasm to make a difference and provide them a career path.

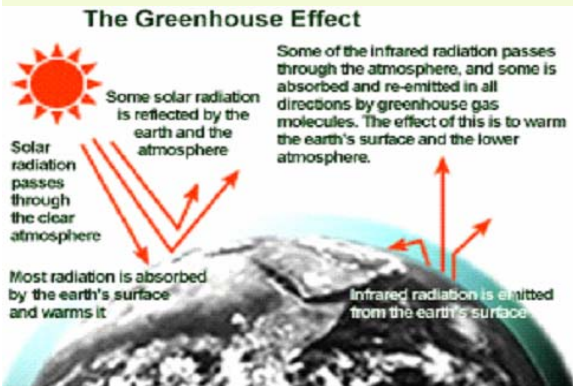

Electric Power - Generation by Fuel Type:

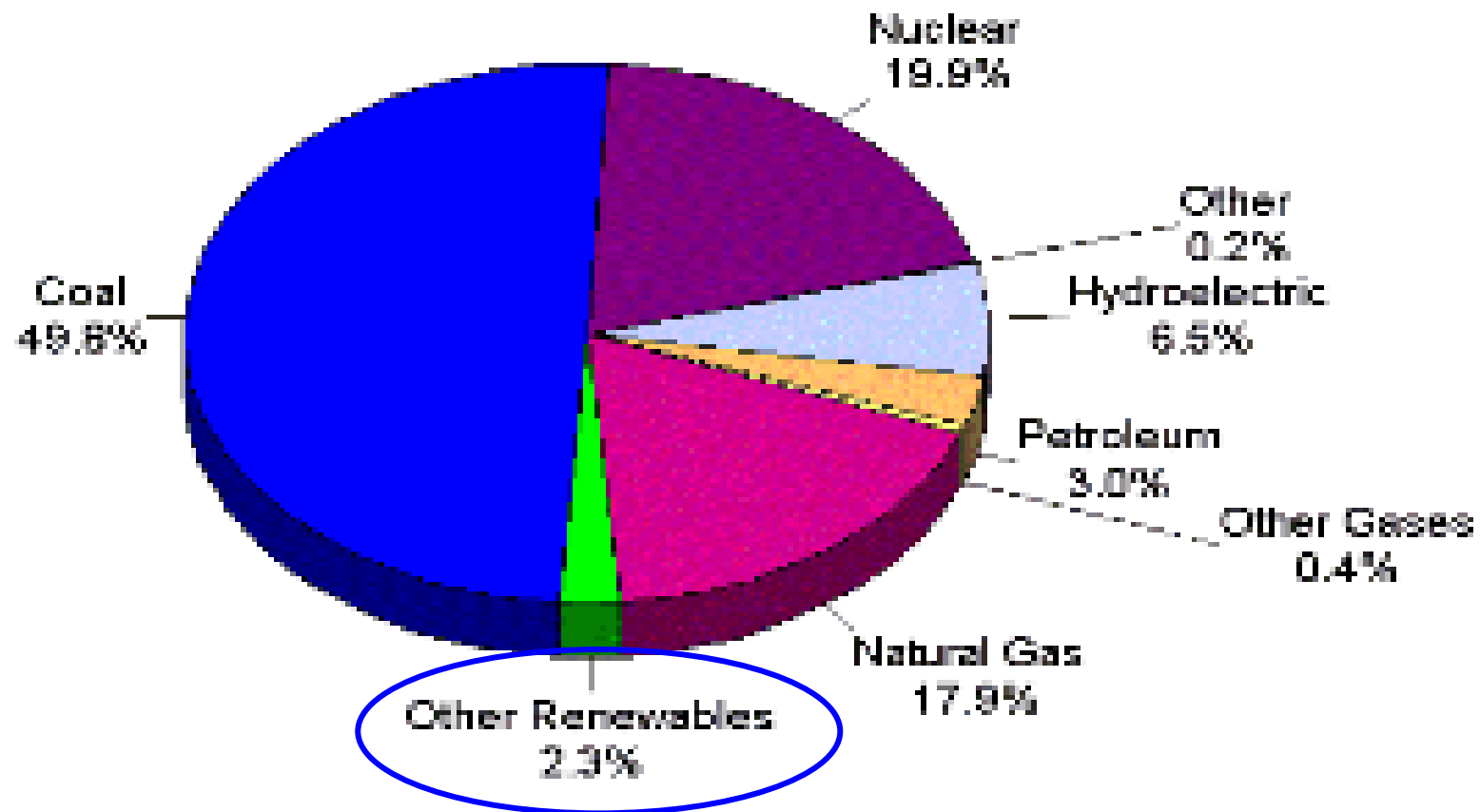

Electricity from Renewables:

- Wind
 - ◆ On-land
 - ◆ Offshore
- Photovoltaic
- Wave Energy
- Geothermal

Nuclear (?)

**Nuclear Power in Minnesota and the Nuclear Power Renaissance:
Terry Pickens Director, Nuclear Regulatory Policy, Xcel Energy**

www.ece.umn.edu/groups/power

Internet-based Monthly seminars (seminar 14, June 27, 2009)

Renewable Portfolio Standards (RPS)

“Wind can supply up to 20%
of U.S. electricity”
President Bush,
February 21, 2006

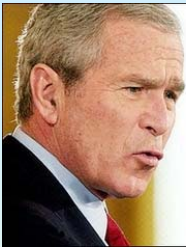

Governor Pawlenty signs
renewable energy law



WIND

DOE estimates offshore resources to be 900,000 MW.

United States - Wind Resource Map

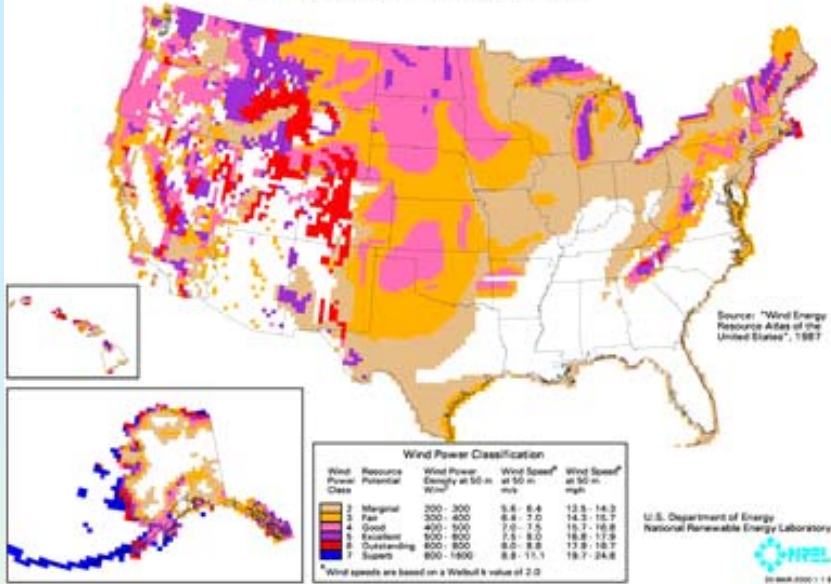

Cost of Electricity

- Coal-Fired: 5.0- 6.0 ¢/kWh
- Single-Cycle Gas-Fired: 20 ¢/kWh
- Combined-Cycle Gas-Fired: 8.0-10.0 ¢/kWh
- Wind Turbines:
 - 6.0 ¢/kWh with PTC*
 - 8.0 ¢/kWh w/o PTC*

*PTC – 1.9 ¢/kWh



“ The new wind projects account for about 30% of the entire new power-producing capacity added nationally in 2007 ”



Solar is today where wind was 5-8 years ago.

Sodium Sulfur Battery Energy Storage and its Potential to Enable Further Integration of Wind

By Xcel Energy



Efficient End-Use:

Lighting 19%

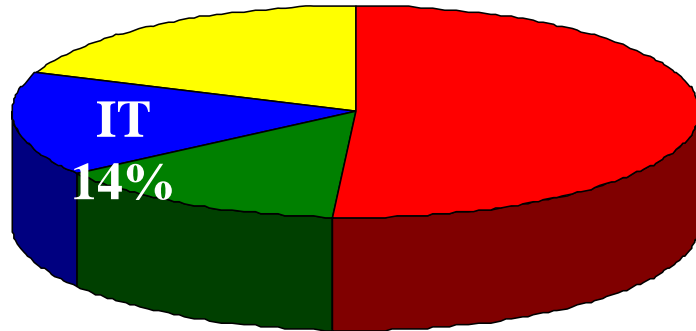

HVAC 16%

Motors 51%

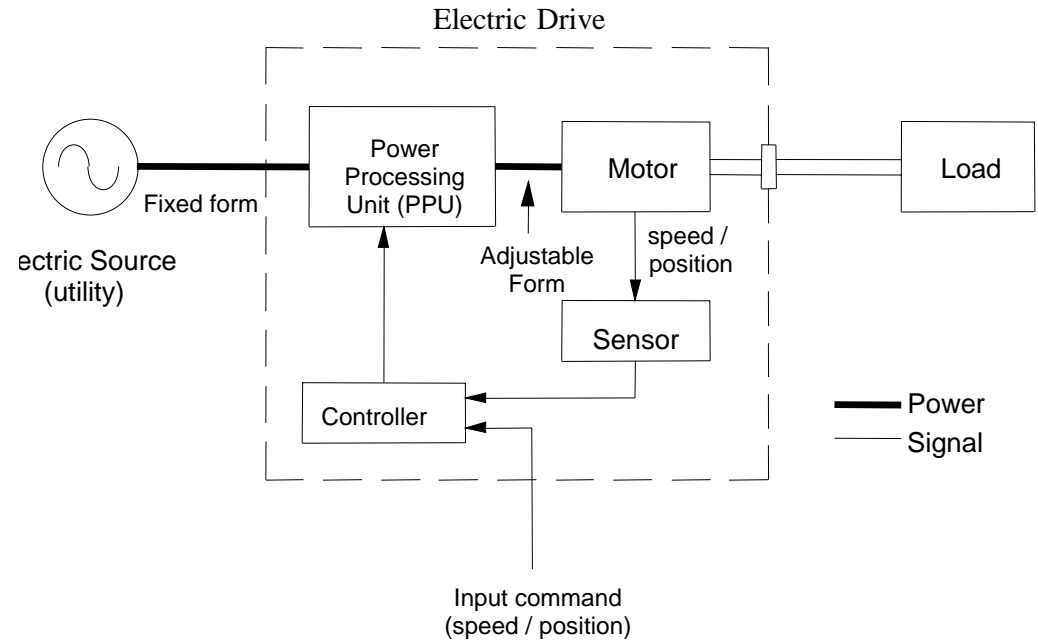

Adjustable Speed Drives



Plug-in Hybrid?



CFL



LED Lighting

Geothermal Heat Pumps



Warren Gretz, NREL/PIX06534

For a home of 1,500 square feet with a good building envelope and a geothermal heat pump, energy costs are about one dollar a day.

Role of Adjustable-Speed Drives

©Copyright 2009 NREL

Closed-Loop Systems Horizontal

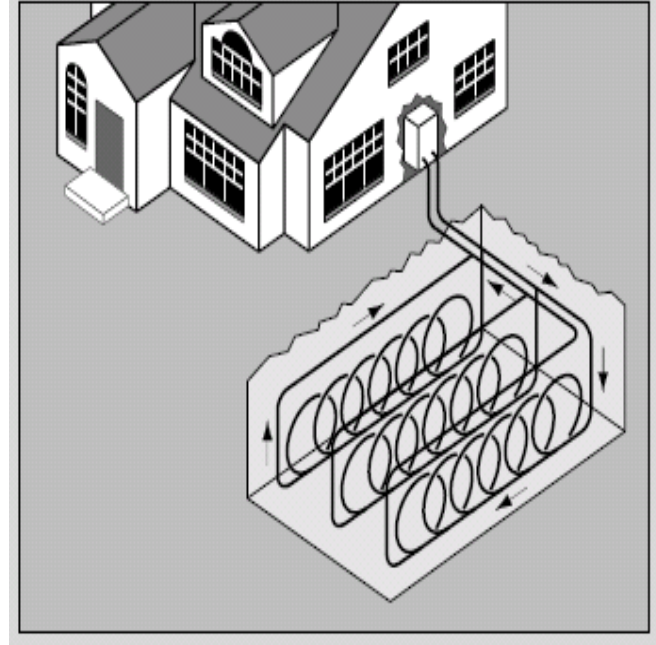

Plug-In Hybrid Electric Vehicles

Flywheel Energy Storage

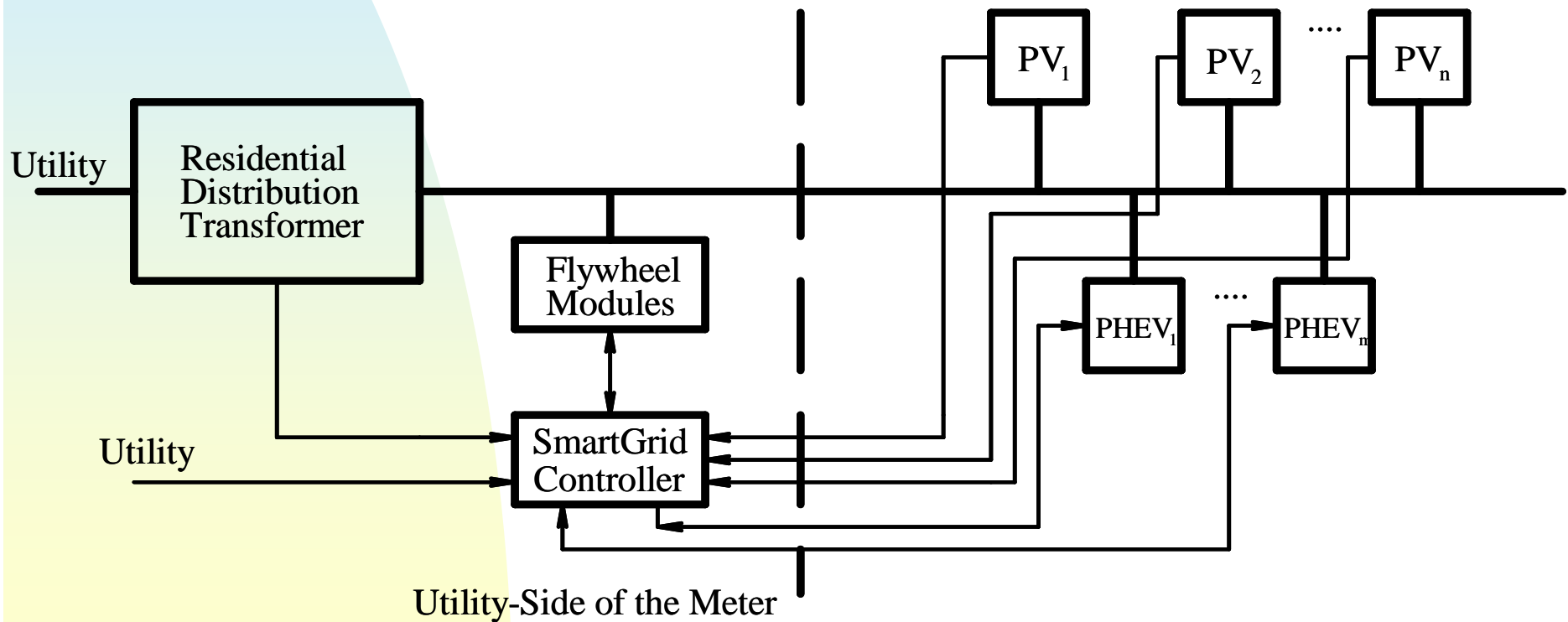
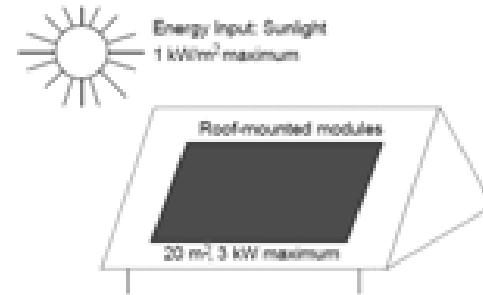
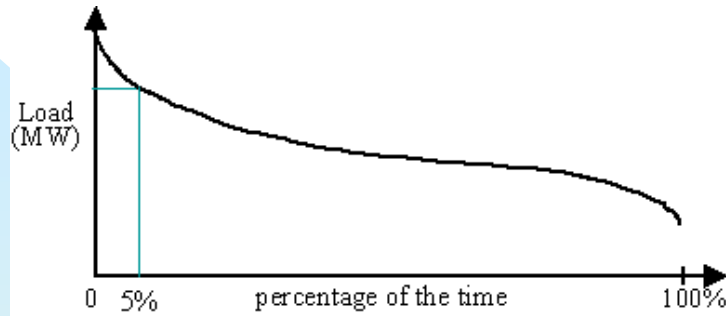

Flywheel Energy Storage

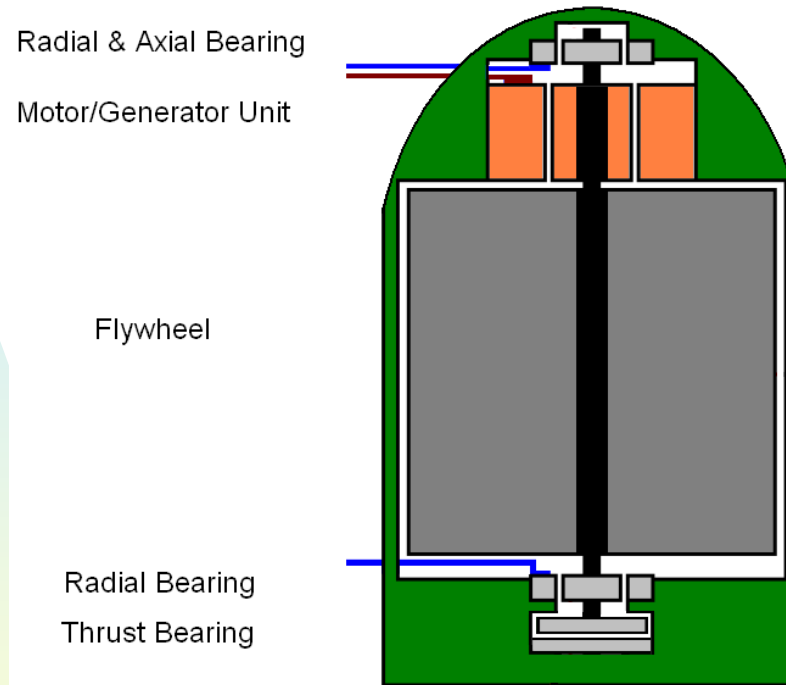

Our Response:

Design an **Integrated Curriculum**

◆ **Benefits Students**

- ☞ Meets Breadth and Depth Requirements
- ☞ Independent of Workforce Shortages
- ☞ Emphasizes Renewables

Wind Generation: Example of an Integrated System

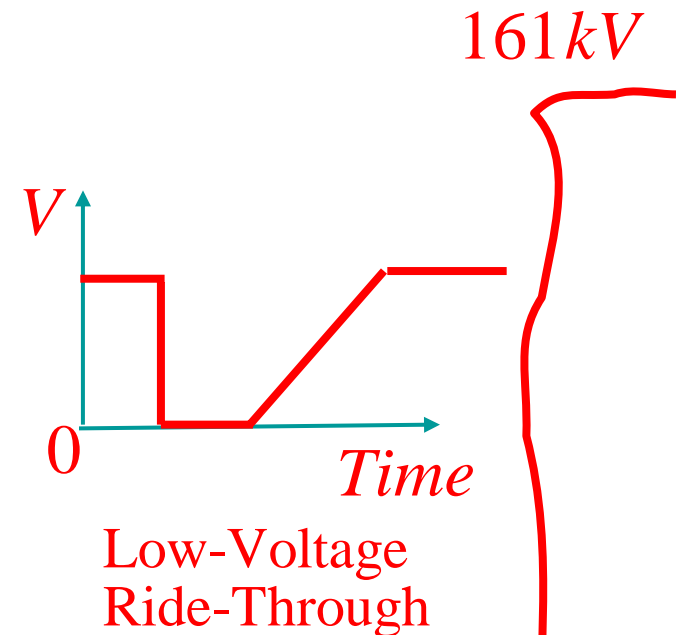
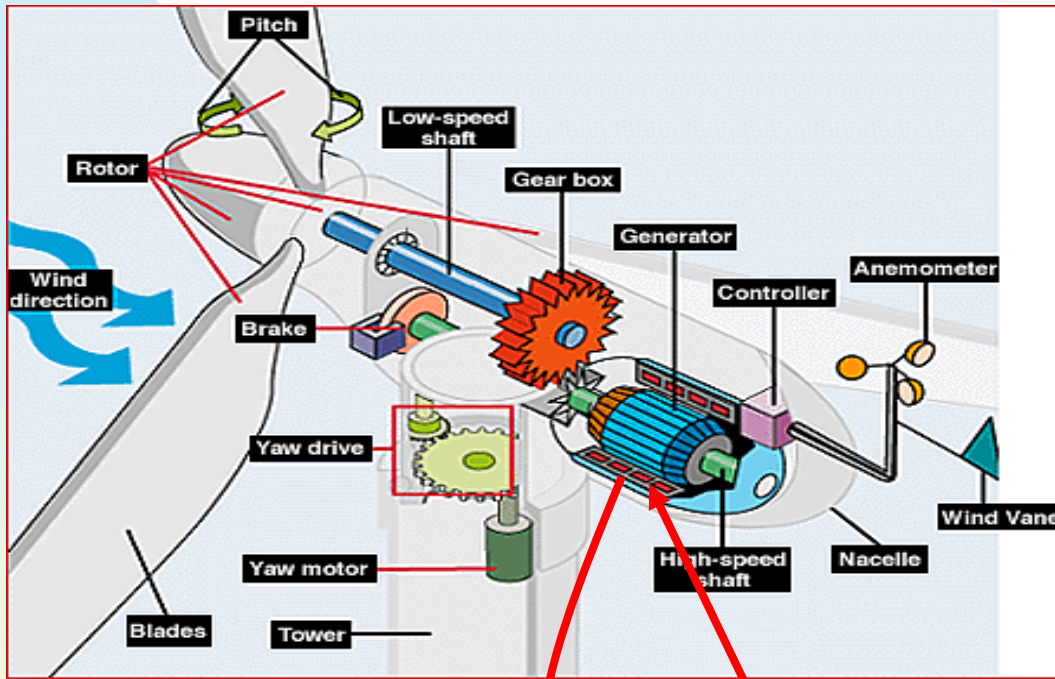

$0 - 690\text{ V}$
 $10 - 60\text{ Hz}$

Generator

Power Electronics Converter

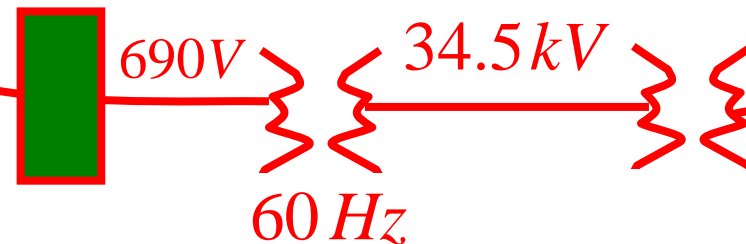

Electric Energy Systems Focus Area: Only 3 Senior Technical-Elective Courses

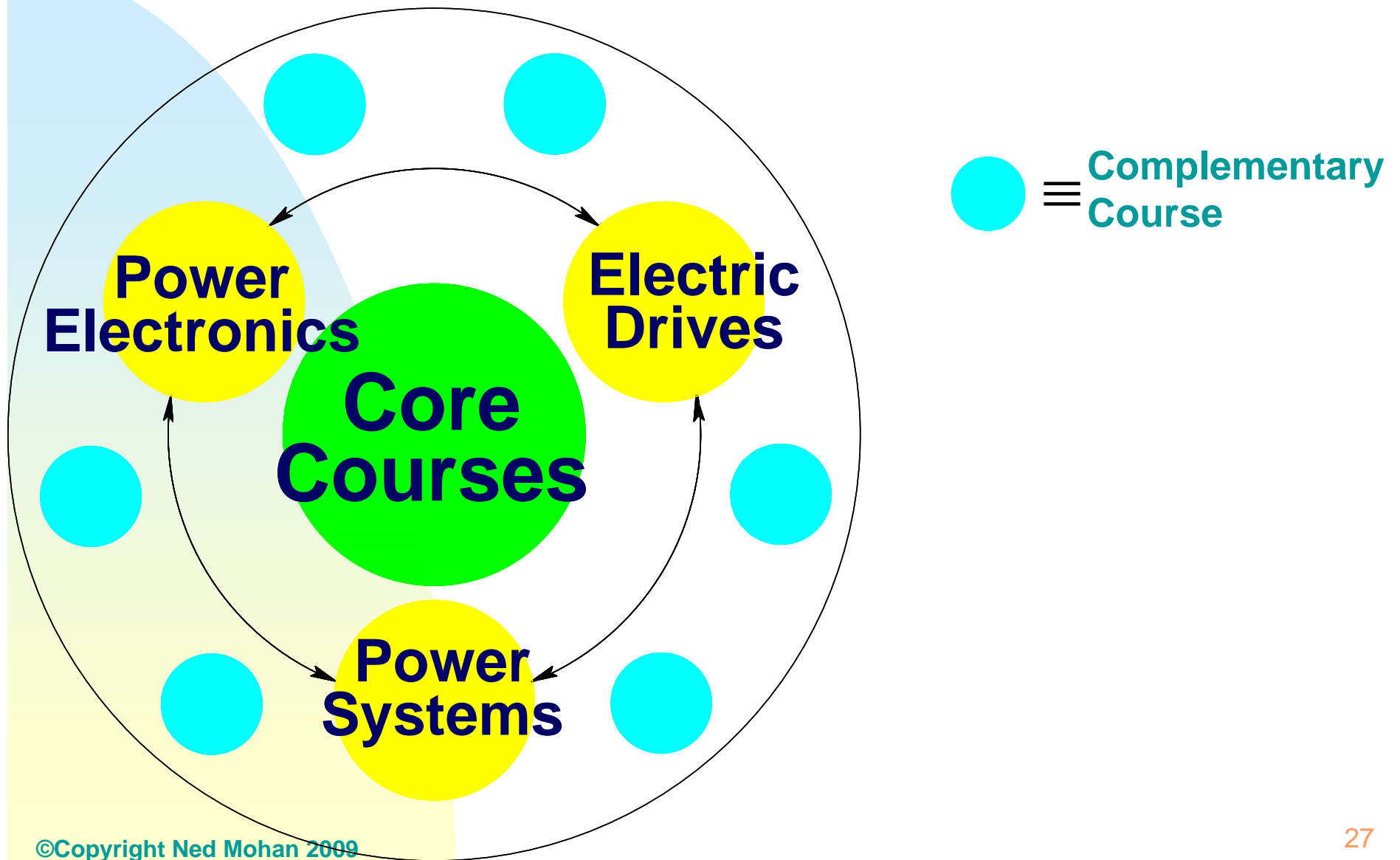

Core Courses

(First 3 Years; common to all focus areas)

- Physics
- Chemistry
- Math
- Liberal Arts Requirements
- Basic Electric Engineering Courses
 - Circuits and Systems: dc, step-response, steady state ac, Laplace Transform, Fourier Transform, Phasor Analysis
 - Electronic Circuits
 - Electro-Magnetic Fields

Students can choose one of these Focus Areas in the 4th Year:

1. **Electric Energy Systems**
2. Control
3. Computer Engineering
4. Optics
5. VLSI
6. Digital Signal Processing
7. Magnetics
8. Micro-Electronics
9. MEMS, Nano
10. Solid-State Devices

Breadth and Depth Requirements in Senior Electives at UMN:

- Breadth Requirement
 - ◆ At least one course each in four areas
- Depth Requirement
 - ◆ At least two courses in one area
- Similar at Numerous Other Universities

Suggested Complementary (5 to 6) Senior Technical-Elective Courses:

- **Analog and Digital Control courses**
- **Embedded Controllers: DSP and FPGAs courses**
- **Course on Analog Circuit Design**
- **Programming Language courses**
- **Course on Heat Transfer**
- **Course on Thermodynamics**

A Senior-Design Project Required

Continuing Education:

- ◆ As a Graduate Student – MS or PhD
- ◆ Internet-based Distance Education
 - as a Graduate Student
 - as a Non-Degree Student
- ◆ Short Courses for CEUs or PDH

Benefits of Our Approach:



- Broader range of topics in each course
- More in-depth coverage!
- Students are broadly trained
- Domestic Graduate Students (?)

Audience Response:

Undergraduates will Benefit if Broadly Trained (Graduate School is the place to Specialize):

- AGREE – press A
- Somewhat AGREE – press B
- DISAGREE – press C

Pedagogy:

- Online Homework Problems
 - ◆ TA as a co-Teacher
- Student Response System
- Field Trips



Gender Equality: A Goal

Increasing Student Enrollments –

2008-2009 at UMN: **Power Systems (PS): 90**
Power Electronics (PE): 118
Electric Drives (ED): 125

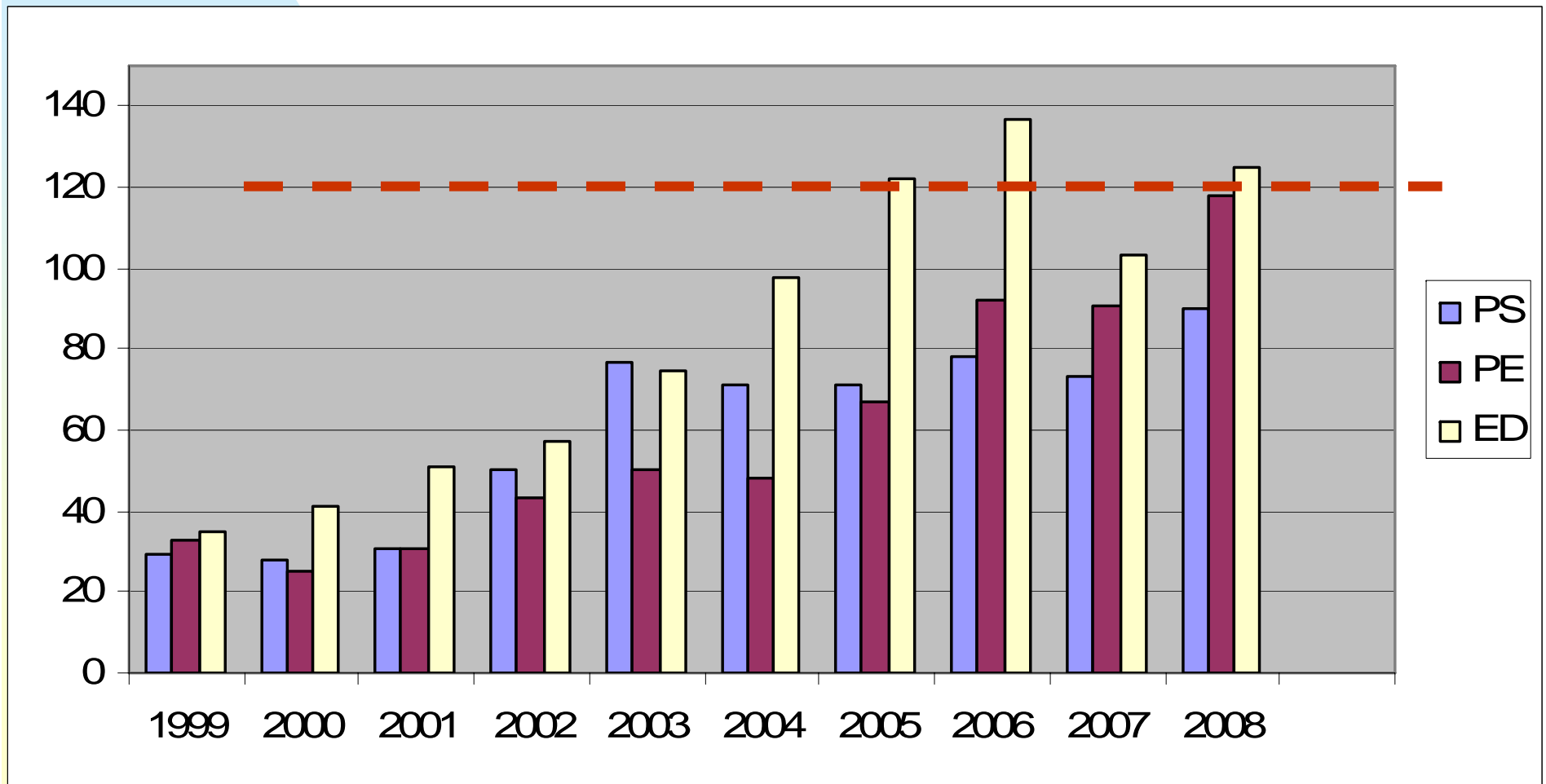

Mission:

Affect Curricular Change in at least **175**
Schools Nationwide

- Adapted already in various combinations
at **~100** schools

Distance Education:

- **For Practicing Engineers**
- **University Education (?)**

- Ron Fitch and Heather Dorr – 1:45-2:00 PM

Available Resources:

- All Necessary Materials
 - Course Learning Objectives
 - Textbooks (Presentation Slides, Solutions Manuals)
 - Labs
 - Online Assessment Problems
- Annual Faculty Workshops to Exchange ideas
 - Join the Community of Teaching Scholars
- Weeklong Summer Immersion Workshops
 - Travel Expenses paid plus honorarium

Workshop Agenda

10:30-12:00 p.m.

Details of the Proposed Curriculum and UMN Developed Laboratories

- **Power Electronics – Bill Robbins**
- **Power Systems – Bruce Wollenberg**
- **Electric Drives – Paul Imbertson**

1:30-1:45 PM

Description of Corvallis, OR: Site of 2009 Summer Faculty Workshop – Ted Brekken

1:45-2:00 PM

Distance Education – Ron Fitch, Heather Dorr

3:00-3:30 PM

Open Discussion of UMN-Proposed Curriculum and Online Courses: Chaired by Julie Ellis

3:30-5:00 PM

Invited Poster Session (Coffee + Cash Bar)

6:00-7:00 PM

- ◆ **Curriculum Advisory Board Meeting –**
Chaired by Nari Hingorani
- ◆ **ECE Dept Heads Working Group Meeting –**
Chaired by Marc Bodson

7:00-8:30 PM Banquet (spouses invited):

Presentation by Dr. Terje Gjengedal, VP-Statkraft, Norway on “Energy for the Future- Possibilities and Challenges”

Saturday

7:00-8:00AM Continental Breakfast

8:00-10:00 AM **Reports of the Working Groups**

10:30-12:00

Presentations from Industry on Educational Needs

- Yakout Mansour – President and CEO – California ISO
- Danny Spear – General Dynamics Electric Boat
- Waleed Said – Hamilton Sundstrand
- Noel Schultz – IEEE Power Engineering Society

1:30-3:30 PM

Designing 2nd Courses (Entry-Level Graduate Courses) -
Chaired by Noel Schultz

3:30-5:00 **Summation and Action Plan**

5:00-5:30 **Certificates of Appreciation**